

Design Poul Henningsen

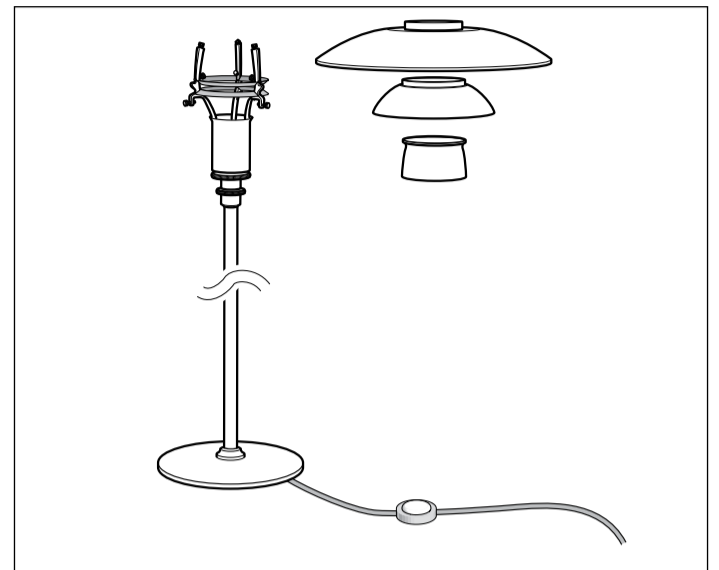
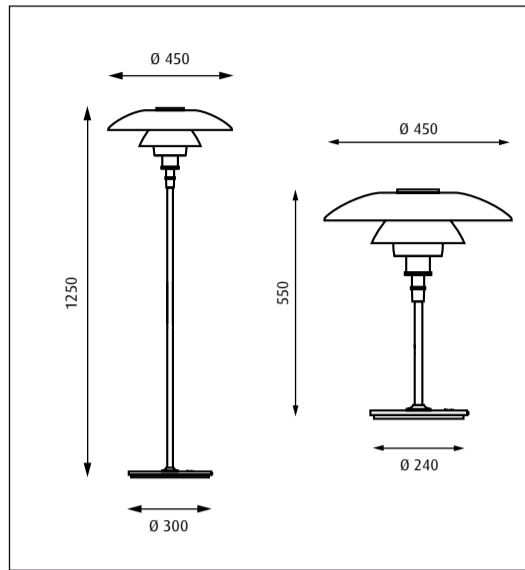

27092-65

Lyskilde Light source Leuchtmittel Ljuskälla Sorgenti luminose Source lumineuse Fuente de luz	Spænding/frekvens Voltage/frequency Spannung/frequenz Spänning/frekvens Tensione/frequenza Voltage/frequence Tensión/ frecuencia	Vægt Weight Gewicht Vikt Peso/ingombro Poids Peso	Isolationsklasse Electric shock protection Schutzklasse Isolationsklass Classe di isolamento Protection au choc électrique Clase de aislamiento	Tæthedsklasse Ingress protection Ingress protection Kapslingsklass Grado di protezione Indice de protection Clase de protección
<b>1x150W E27</b> <small>More info <a href="http://www.louispoulsen.com">www.louispoulsen.com</a></small>	<b>Max 230V/50Hz</b>	<b>9,0 kg</b>	<b>Cl. II</b>	<b>IP 20</b>

#### DA

Støv aftørres med en tør, blød klud. Fedtpletter og lignende kan fjernes med en blød klud opvredet i lunkent vand (<50° C) tilsat mildt rengøringsmiddel.  
Brug aldrig rengøringsmidler med slibemiddel eller opløsningsmidler.

**Specifikt for mundblæst glas:** Skal rengøres i kold tilstand. Alt vand skal være fordampet inden lampen tændes igen.

#### EN

Wipe off dust with a dry, soft cloth. Remove greasy spots etc. with a soft cloth dampened in lukewarm water (<50° C) with a mild detergent.  
Never use detergents containing abrasives and solvents.

**Mouth-blown glass in specific:** Must be cleaned in cold condition. All water must be evaporated before the lamp is lit again.

#### DE

Staub bitte mit einem trockenen, weichen Lappen abwischen. Fettflecke und dgl. mit einem feuchten, in lauwarmem Wasser (<50° C) mit mildem Reinigungsmittel ausgewrungenen Lappen entfernen.  
Niemals Reinigungsmittel mit Schleifmittel oder Lösungsmittel verwenden.

**Speziell für mundgeblasenes Glas:** Glas nur in trockenem Zustand reinigen. Nachprüfen, dass das Wasser vor dem Wiedereinschalten der Leuchte verdampft ist.

#### SV

Lampan dammtorkas med en torr, mjuk trasa. Fettfläckar tas bort med ljummet vatten (<50° C) utblandat med mildt rengöringsmedel.

Använd aldrig rengöringsmedel som innehåller slipmedel eller lösningsmedel.

**Specifikt för munbläst glas:** Ska rengöras i kallt tillstånd. Tänd lampan först då glaset är helt torrt.

#### IT

Pulire la polvere esterna con un panno morbido e asciutto. Rimuovere macchie di grasso ecc. con un panno morbido inumidito in acqua tiepida (<50° C) e con un detergente leggero.

Non usare mai detersivi contenenti abrasivi o solventi.

**Pulizia del vetro soffiato:** deve essere pulito quando e' freddo. Tutta l'acqua deve essere evaporata prima della riaccensione della lampada.

#### FR

Essuyez la poussière avec un chiffon sec et doux. Enlevez les points de salete etc. Avec un chiffon doux imprégné d'eau claire tiède et de détergent doux. Ne jamais utiliser de détergents contenant des abrasifs et des solvants.

**Verre soufflé a la bouche. Traitement spécifique:** Doit être nettoyé à froid. Toute trace d'eau doit être enlevée avant d'allumer la lampe à nouveau.

#### ES

Limpiar con paño seco y suave. Quitar manchas de grasa y otras con paño suave humedecido con agua templada (<50° C) con detergente poco agresivo.

Nunca use detergentes que contengan abrasivos y disolventes.

**Vidrio soplado:** Limpiar en frío. Esperar evaporación del agua antes de encender de Nuevo.

