

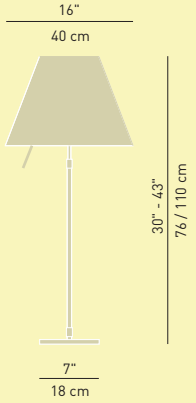

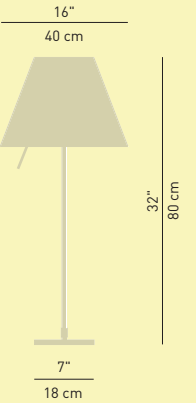



**table**

	
<b>D13 (dimmer)</b>	<b>D13i.f.</b>
 100W A-19 soft white med. base	 150W A-19 soft white med. base

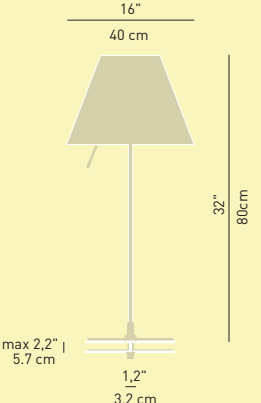

	
<b>D13i.f.p.t.</b>	
 150W A-19 soft white med. base	

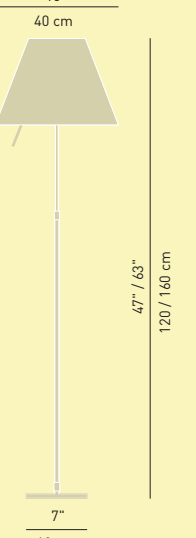
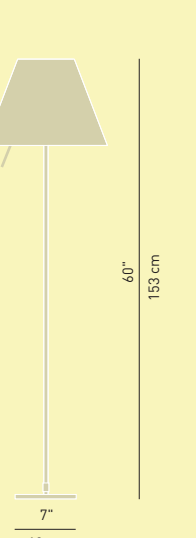
by lightly touching the sensorial dimmer close to the light source, the lamp may be turned off and on through four levels of luminous intensity

**floor**

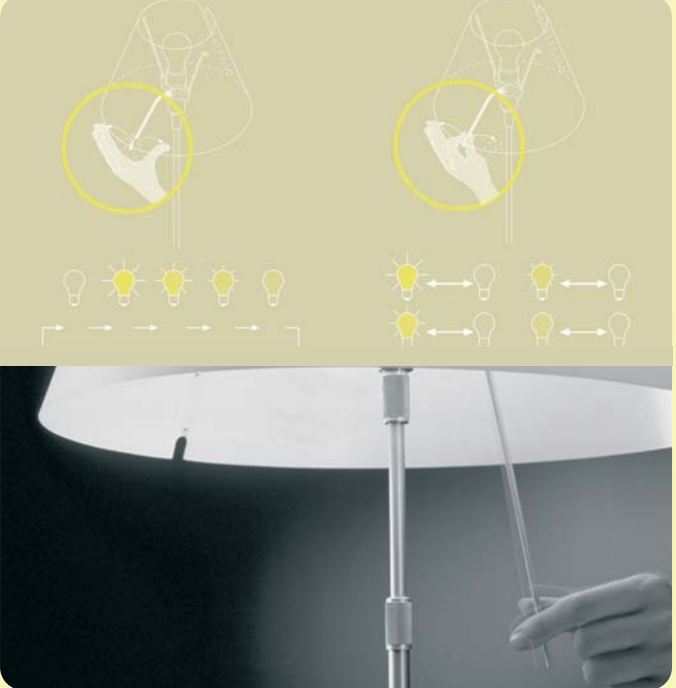
	
<b>D13t. (dimmer)</b>	<b>D13t.i.f.</b>
 100W A-19 soft white med. base	 150W A-19 soft white med. base



<b>materials</b>						 made of <b>makrolon</b> the high-tech material	
aluminium body    interchangeable polycarbonate silkscreened shade							
<b>structure finishes</b>							
							
alu							
<b>diffusor finishes</b>							
orange	white	blue	pistachio	red			

D13

costanza

paolo rizzato

LUCE  
PLAN

## suspension

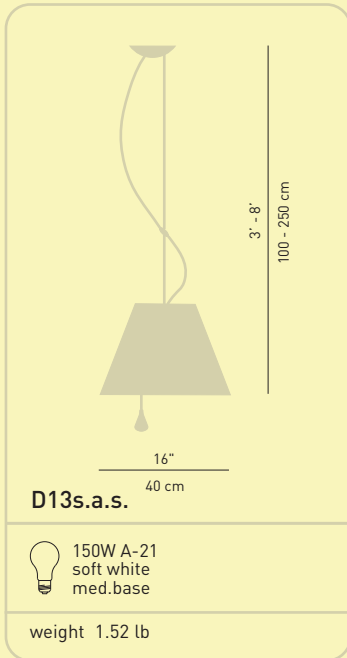

light, washable  
shade rests on two  
points of balance;  
rocks if bumped



thanks to the counterweight,  
the lamp can be adjusted  
to various heights



### materials

aluminium body steel counterweight interchangeable polycarbonate silkscreened shade

### suspension version finishes

white rosette  
opaque chromium-plated counterweight

### shades

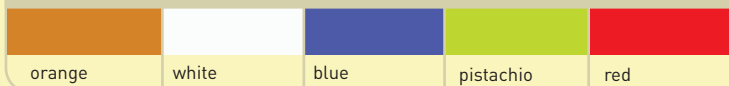

made of  
**makrolon**<sup>®</sup>  
the high-tech material

